

## PERFORMANCE OF COUPLED ED-TETHER / ION THRUSTER SYSTEM

Juan R. Sanmartin<sup>1</sup> and Mario Charro  
 E.T.S.I. Aeronauticos, Universidad Politecnica de Madrid  
 Plaza Cardenal Cisneros, 3, 28040 Madrid, Spain  
 Phone: +34913366302 Fax: +34913366303  
 e-mail: <sup>1</sup>jrs@faia.upm.es

### Abstract

Use of propulsion systems that couple electrodynamic tethers to ion thrusters, as suggested in the literature, is discussed. The system establishes electrical contact with the ionospheric plasma, at the anodic end of the tether, by ejecting ions instead of collecting electrons; also, the ion thruster adds its thrust to the Lorentz force on the tether. In this paper, we analyze the performance of this coupled system, as measured by the ratio of mission impulse (thrust times mission duration) to the overall system mass, which includes the power subsystem mass, the tether subsystem mass, and the propellant mass consumed in the ion thruster. It is shown that a tether acting by itself, collecting electrons at its anodic end, substantially outperforms the coupled system for times longer than a characteristic time of the ion thruster, for which propellant mass equals the power subsystem mass; for shorter times performances are shown to be similar.

### I. Introduction

Ion Thrusters, and in general electrical propulsors, are more efficient than chemical rockets for missions that allow long times, requiring low thrust. In turn, electrodynamic (ED) tethers are much more efficient than ion thrusters for much longer times. This can more than balance the facts that tether-thrust might be ambient-plasma dependent, and that it exhibits low pointing accuracy. Further, those facts in the end would not hinder the slow average action of ED tethers.

The standard ED tether ejects electrons at a (cathodic) end, typically through a hollow cathode (HC), and collects electrons passively, either at the anodic end, as in the *TTSIR* mission,<sup>1</sup> or over a segment of tether left bare of insulation and coming out positively biased;<sup>2</sup> anodic use of a HC was tested in the *PMG* mission.<sup>3</sup> It has now been suggested that, instead of collecting electrons, ions could be ejected at the anodic tether end by an Ion Thruster, which, furthermore, would add to the propulsive capability of the system.<sup>4</sup>

In ion thrusters, electrons from a HC are also emitted immediately downstream in the ion beam, to limit space-charge effects that would affect thruster performance (and would charge the attached spacecraft). In the suggested ED Tether / Ion Thruster hybrid scheme, the thruster would operate, without its neutralizing HC, at one end of the tether, and the HC would operate at the other end, the neutralization current that would flow through the tether allowing the standard Lorentz thrust by the geomagnetic field. In order for the system to work, the ion thruster needs be able to function without having its neutralizer operating in the vicinity, but, rather, kilometers away, i.e. effectively without neutralizer. Space charge spreading of the ion beam makes thrusters operate less efficiently; the higher the beam divergence the less delivered thrust and specific impulse, for the same input power. Hopefully, the reduction in propulsive efficiency might be low in new-generation ion thrusters for space exploration, which will have lower beam densities and higher exhaust velocities (higher specific impulses).

The suggested ED Tether / Ion Thruster hybrid system, combining ED-tether propulsion and a modified electrostatic propulsion, was said to merge the propellant-less propulsion capability of electrodynamic tethers and the efficient propulsion capability of electric propulsion, with any increase in mass with respect to the ion thruster, or the ED tether, working alone, to be assessed on a case-by-case basis depending on the application.<sup>4</sup> It is here shown, however, that full account of all masses and due consideration of mission duration show the suggested hybrid system substantially outperformed by ED-tethers for their long-mission niche, and performing similarly to ED-tethers and ion thrusters otherwise.

### II. Mass-to-impulse ratio in space propulsion

The simpler figure of merit for space thrusters is the ratio between mass of the system dedicated to thrusting and total impulse required by the mission; that ratio should be minimum. Reboost of the International Space Station and 'space-tug' operations are examples of missions well characterized by a total impulse  $F\tau$ . For a chemical rocket, mass is basically propellant mass, which is *mass-flow-rate*  $\dot{m}$  times *mission duration*  $\tau$ , whereas mission impulse is duration  $\tau$  times *thrust* ( $F = \dot{m} v_{exh}$ ); here  $v_{exh}$  is the velocity of gases at exhaust. We are ignoring for simplicity a correction from tankage and plumbing. One then has

$$\frac{\text{Mass of thrusting system}}{\text{Total mission impulse}} = \frac{\dot{m} \tau}{F \tau} = \frac{1}{v_{exh}} \equiv \frac{1}{g_0 \times \text{specific impulse}} \quad (1)$$

The greater the specific impulse the better, but there are clear limitations to how large the specific impulse (or how large the exhaust velocity) can be in case of chemical combustion.

One way to move to greater exhaust velocities is through electrical propulsion, which makes use, however, of a power plant that adds to the mass of the system. If  $W_s$  is the supply power,

$$W_s = F v_{exh} / 2\eta = \dot{m} v_{exh}^2 / 2\eta \quad (2)$$

with  $\eta$  the propulsive efficiency, and  $\beta$  is the inverse specific power of the supply plant, one arrives at<sup>5</sup>

$$\frac{\text{System mass}}{\text{Mission impulse}} = \frac{\dot{m} \tau + \beta W_s}{F \tau} = \frac{1}{v_{exh}} + \frac{\beta v_{exh}}{2\eta \tau} \quad (3)$$

$$\Rightarrow \frac{1}{v_{exh}} \left( 1 + \frac{\tau_{exh}}{\tau} \right), \quad (3')$$

$$\tau_{exh} \equiv \frac{\beta v_{exh}^2}{2\eta} \approx 1.14 \times \beta \left( \frac{\text{kg}}{\text{kW}} \right) \times \left( \frac{v_{exh}}{30 \text{ km/s}} \right)^2 \times \frac{0.65}{\eta} \text{ weeks}. \quad (4)$$

Typical values of state-of-the-art Ion Thrusters are  $\eta \sim 0.65$ ,  $v_{exh} \sim 30$  km/s (over 10 times greater than chemical rocket values); corresponding values for Hall thrusters are  $\eta \sim 0.50$ ,  $v_{exh} \sim 15$  km/s.<sup>6</sup>

Only for  $\tau \gg \tau_{exh}$ , however, does the mass-to-impulse ratio in Eq. (3') reaches down to the value of inverse exhaust velocity,  $1/v_{exh}$ . In fact, for  $\tau \ll \tau_{exh}$ , that ratio diverges, any gain in using electrical propulsion being fully lost. It is clear that one cannot discuss the advantages of electrical versus chemical propulsion without reference to mission duration. This is already manifest in the Tsiolkovsky equation for the standard mission requiring a thruster to impart some velocity increment  $\Delta v$  to a payload, which, in the case of electrical propulsion, reads<sup>7</sup>

$$\Delta v = v_{exh} \times \ln \left| \frac{1 + \tau_{exh} / \tau}{\text{payload mass ratio} + \tau_{exh} / \tau} \right|. \quad (5)$$

Again, we have  $\Delta v$  vanishing for  $\tau \ll \tau_{exh}$ .

An ED bare-tether uses no propellant, though expellant is consumed at the hollow cathode. The expellant mass-flow-rate, however, is 2-3 orders of magnitude smaller than at an electrical propulsor and can be fully ignored.<sup>5</sup> One then has

$$\text{System mass} \approx \beta W_s + \alpha_t \times \rho A_t L_t, \quad (6)$$

$$F = I_{av} L_t B_{\perp}, \quad (7)$$

where  $\alpha_t \sim 2-3$  accounts for tether-related hardware (*deployer / ballast mass*), and  $I_{av}$  and  $B_{\perp}$  are current averaged over tether length and geomagnetic component perpendicular to the orbital plane. Finally, one finds<sup>7</sup>

$$\frac{\text{System mass}}{\text{Mission impulse}} = \frac{\beta W_s + \alpha_t \rho A_t L_t}{I_{av} L_t B_{\perp} \tau} = \frac{\beta U_{orb} W_s}{\tau W_m} + \frac{\alpha_t \rho U_{orb}}{\tau \sigma_c E_m^2 i_{av}} \quad (8)$$

$$\Rightarrow \frac{\beta U_{orb}}{\tau} \left[ \frac{1}{\eta_t} + \frac{1}{\tilde{E}_m^2 i_{av}} \right], \quad (8')$$

where  $W_m = I_{av} E_m L_t$  is the magnetic (thrust) power,  $E_m = U_{orb} B_{\perp}$  the motional field,  $\eta_t = W_m / W_s$  the tether propulsive efficiency,  $i_{av} = I_{av} / \sigma_c E_m A_t$  the average current normalized with the short-circuit current (in absence of power supply),  $\tilde{E}_m = E_m / \sqrt{\alpha_t \rho / \beta \sigma_c}$  a normalized motional field that can be checked to be typically around unity, and  $\rho$ ,  $\sigma_c$ ,  $A_t$ , and  $L_t$  tether density, conductivity, cross-section area and length.

Both  $\eta_t$  and  $i_{av}$  take values of order unity that come out from detailed bare-tether analysis.<sup>5</sup> Comparing now Eqs.(3, 3') with Eq. (8') clearly shows a much lower mass-to-impulse ratio for the ED-tether (i.e., equivalent "specific impulse" of ED-tether much greater than  $v_{exh}/g_0$ ) in case  $\tau \gg \tau_{exh}$ ; they are comparable in case  $\tau \sim \tau_{exh}$ .

### III. Performance of coupled ED-Tether / Ion Thruster

There are basically two possible arrangements, either having the power supply at the bottom (Fig.1) or at the top (Fig.2), though only the second one would allow the tether be positive relative to the plasma, and thus to operate as a bare tether. In either case, neglecting the small bias at the HC, one has voltage and power supply given as

$$\varepsilon_s = E_m L_t + Z_t I + V, \quad W_s = \varepsilon_s I = VI + E_m L_t I + Z_t I^2. \quad (9a, b)$$

where  $Z_t = L_t / \sigma_c A_t$  is the tether resistance and  $\eta \times VI$  is the ion-thruster output power,  $\frac{1}{2} \dot{m} v_{exh}^2$ . We then have

$$\text{System mass} \approx \dot{m} \tau + \beta W_s + \alpha_t \rho A_t L_t, \quad (10)$$

$$F = \dot{m} v_{exh} + I L_t B_{\perp}, \quad (11)$$

yielding a mass-to-impulse ratio

$$\frac{\text{System mass}}{\text{Mission impulse}} = \frac{\dot{m} \tau + \beta \left( \frac{\dot{m} v_{exh}^2}{2\eta} + E_m L_t I + \frac{L_t I^2}{\sigma_c A_t} \right) + \alpha_t \rho A_t L_t}{(\dot{m} v_{exh} + I L_t B_{\perp}) \tau} \quad (12)$$

$$\Rightarrow \frac{\mu}{1 + \mu} \left[ \frac{1}{v_{exh}} + \frac{\beta v_{exh}}{2\eta \tau} \right] + \frac{\beta U_{orb}}{\tau} \times \frac{1 + i}{1 + \mu} + \frac{U_{orb}}{\tau} \times \frac{\alpha_t \rho / \sigma_c E_m^2}{(1 + \mu) i}, \quad (12')$$

where we defined  $\mu \equiv \dot{m} v_{exh} / I L_t B_{\perp}$ .

We rewrite Eq. (12') as

$$\frac{\text{System mass}}{\text{Mission impulse}} \times v_{exh} = \frac{\mu}{1 + \mu} \left( 1 + \frac{\tau_{exh}}{\tau} \right) + \frac{1}{1 + \mu} \times \frac{\tau_{exh}}{\tau} \times \left[ \frac{2U_{orb}}{v_{exh}} \times \frac{\eta}{\eta_{eff}} \right] \quad (13)$$

where

$$\frac{1}{\eta_{eff}} = 1 + i + \frac{1}{\tilde{E}_m^2 i}. \quad (14)$$

We note that for well designed bare tethers, the square bracket in Eq. (8') reads as the right-hand-side of (14) with  $i_{av}$  replacing  $i$ .<sup>5</sup>

Cases  $\mu \rightarrow \infty$  ( $\mu = 0$ ) correspond to ion thruster (ED-tether) working alone, the right-hand-side of Eq. (13) taking the respective forms

$$1 + \frac{\tau_{exh}}{\tau}, \quad \frac{\tau_{exh}}{\tau} \left[ \frac{2U_{orb}}{v_{exh}} \times \frac{\eta}{\eta_{eff}} \right], \quad (15a, b)$$

whereas it takes the form

$$\frac{1}{2} \left( 1 + \frac{\tau_{exh}}{\tau} \right) + \frac{1}{2} \frac{\tau_{exh}}{\tau} \left[ \frac{2U_{orb}}{v_{exh}} \times \frac{\eta}{\eta_{eff}} \right] \quad (15c)$$

for a middle hybrid system,  $\mu = 1$ . The limits of the expressions in (15a, b, c) for long times,  $\tau \gg \tau_{exh}$ , are 1, 0, and  $\frac{1}{2}$  respectively. The ED-tether is the clear winner. Note that taking into account the small HC-expellant mass consumed would just turn the zero limit from (15b), corresponding to an "infinite specific impulse", into a 0.01 - 0.001 value.

For  $\tau = \tau_{exh}$ , the expressions in (15a, b, c) become

$$2, \quad [2 U_{orb} \eta / v_{exh} \eta_{eff}], \quad 1 + \frac{1}{2} \times [2 U_{orb} \eta / v_{exh} \eta_{eff}], \quad (15'a, b, c)$$

respectively, which are comparable (the square bracket being around unity for present-day ion-thrusters in LEO), though the plain ED-tether is still the winner. Note that the expected reduction in the efficiency  $\eta$  of an ion-thruster working in the hybrid scheme, and the higher exhaust velocity of future ion-thrusters, will both enhance the advantage of the plain ED-tether, though they will increase  $\tau_{exh}$  too.

#### IV. An ED-Tether / Ion Thruster system

Consider now the system discussed as example in Ref. 4. Its ion thruster had

$$\begin{aligned} \text{specific impulse} &= 4,000 \text{ s}, & \text{thrust } \dot{m} v_{exh} &= 0.2 \text{ N}, \\ \text{power } \dot{m} v_{exh}^2 / 2 \eta &= 5.7 \text{ kw}, & \text{inverse specific power } \beta &= 1/48 \text{ w/kg} \approx 20.8 \text{ kg/kw}, \end{aligned}$$

corresponding to

$$v_{exh} \approx \underline{40 \text{ km/s}}, \quad \eta = \underline{0.7}, \quad \tau_{exh} \approx \underline{39 \text{ weeks}} \quad (\dot{m} = 5 \times 10^{-6} \text{ kg/s}).$$

The tether was a round aluminum wire with

$$\text{radius} = 1 \text{ mm}, \quad L_t = 7 \text{ km}, \quad (\text{tether mass} \approx 59.4 \text{ kg}),$$

the current and Lorentz force being

$$I = 3.2 \text{ A}, \quad IL_t B_{\perp} = 0.44 \text{ N},$$

corresponding to

$$\mu = \underline{0.45}, \quad 1/\sigma_c A_t \approx 0.009 \text{ } \Omega/\text{m} \quad (Z_t = 63 \text{ } \Omega)$$

and yielding

$$B_{\perp} \approx 0.2 \text{ gauss}, \quad E_m \approx 0.15 \text{ V/m} \quad (IE_m L_t \approx 3.36 \text{ kw}, \quad Z_t I^2 = 0.65 \text{ kw})$$

and finally

$$i \approx \underline{0.194}, \quad \tilde{E}_m \approx \underline{1.774} \quad \Rightarrow \quad \eta_{eff} \approx \underline{0.35}.$$

(With a heavy ion-thruster system at the anodic end, we set  $\alpha_t = 2$ , making  $\sqrt{\alpha_t \rho / \beta \sigma_c} \approx 0.086 \text{ V/m}$ .)

The right-hand-side of (13) here reads

$$\frac{0.45}{1.45} \times \left( 1 + \frac{\tau_{exh}}{\tau} \right) + \frac{\tau_{exh} / \tau}{1.45} \times \left( \frac{15}{40} \times \frac{0.7}{0.35} \right),$$

with a *mass-to-impulse ratio*  $\approx 40 \text{ km/s} \times 3.2$  for  $\tau \gg \tau_{exh}$ . This was the value given in Ref. 4 as (equivalent) specific impulse. Note, however, that it is only valid for  $\tau \gg \tau_{exh}$ ; for such times the ( $\mu = 0$ ) ED-tether's equivalent specific impulse,  $40 \text{ km/s} \times 4\tau / 3\tau_{exh}$ , is much greater. Corresponding values for  $\tau = \tau_{exh}$  would be  $40 \text{ km/s} \times 1.45/1.65$  for the hybrid system of Ref. 4, as against  $40 \text{ km/s} \times 4/3$  for the plain ED tether.

We emphasize here that the ED-tether would indeed work. A well designed bare tether, to make the bracket in (8') read as the right-hand-side of (14), would be a thin tape (0.1 mm thin,  $\pi/10$  mm wide to keep mass and resistance), with an upper segment insulated; the greater perimeter would result in increased current collection and ohmic effects. Also, the value  $i \approx 0.19$  above is far from optimal; the supply power  $W_s$  should be made to give a current  $i = 1/\tilde{E}_m \approx 0.56$ , which yields a maximum  $\eta_{eff}$  in Eq. (14).<sup>5</sup>

#### V. Conclusions

We have shown that taking fully into account all system masses, and giving due consideration to mission duration, the suggested hybrid system is substantially outperformed by ED-tethers for their long-mission niche, and performs similarly to ED-tethers and ion thrusters otherwise. The point is that coupling an ion thruster to an ED-tether system increases the mass-to-impulse ratio of the ion thruster but decreases the ratio of the ED-tether (enormously so in case of very long missions). Independently, the hybrid system appears as much more complex than either ion thruster or ED-tether working alone.

#### References

- 1 N.H. Stone and C. Bonifazi, *Geophys. Res. Lett* **25**, 409-412 (1998).
- 2 J.E. McCoy *et al.*, "Plasma Motor-Generator (PMG) flight experiment results", *Proceedings of 4th International Conference on Tethers in Space* (Washington, 10-14 April 1995) pp. 57-82.
- 3 J.R. Sanmartin, M. Martinez-Sanchez and E. Ahedo, *J. Prop. Power* **9**, 353-360 (1993).
- 4 D. Nicolini and W.J. Ockels, "Coupled Electrodynamic Tether/Electrostatic Propulsion System", 28<sup>th</sup> *International*

*Electric Propulsion Conference, Toulouse-France, 17-21 March (2003).*

5 J.R. Sanmartin, R.D.Estes, E.C. Lorenzini and S.A. Elaskar, "The Efficiency of Electrodynamic Tether Systems", submitted to *J. Space. Rockets*.

6 M. Martinez-Sanchez and J.E. Pollard, *J. Prop. Rockets* 14, 688-699 (1998).

7 P. Fortescue and J. Stark, *Spacecraft Systems Engineering*, J. Wiley (1995), Ch.6.

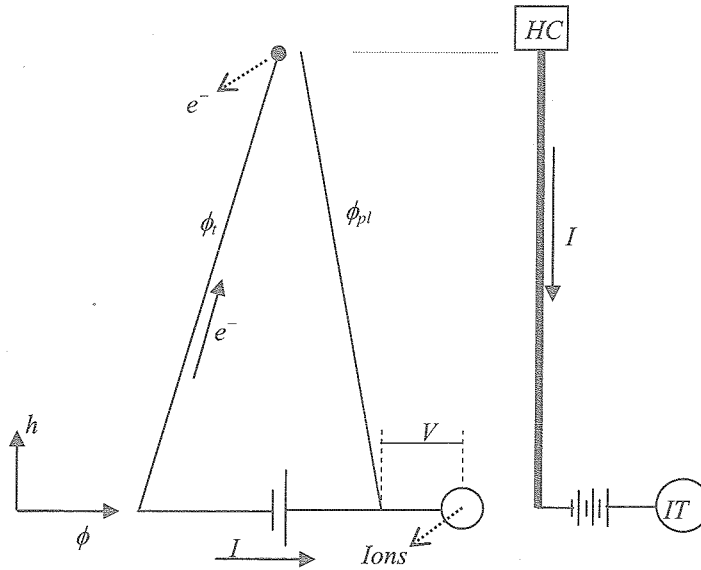

**Fig. 1** Potentials of tether and ambient-plasma versus distance  $h$  from tether bottom

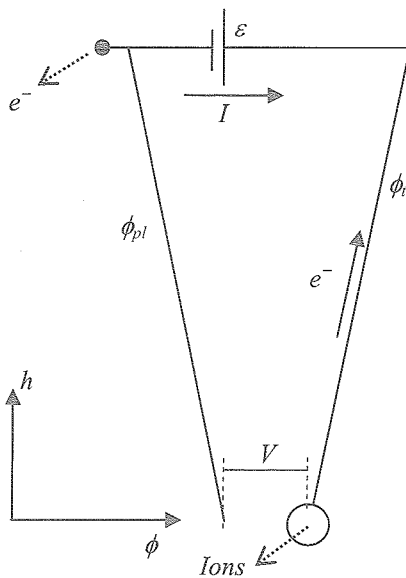

**Fig. 2** Same as Fig.1 for power supply at top