

Experimental measurement of secondary arc plasma parameter on solar array

Takayuki Ose, Hirokazu Masui, Kazuhiro Toyoda, Mengu Cho

Department of Electrical Engineering, Kyushu Institute of Technology
1-1 Sensui Tobata-ku Kitakyushu 804-8550 JAPAN
Tel&fax : +81-93-884-3229
E-Mail : f346407t@tobata.isc.kyutech.ac.jp

Abstract As the power level of geostationary satellites increases, discharge phenomena on solar array are becoming serious threat to safe operation. Arcs on solar array can short-circuit the satellite circuit, decrease the satellite power, and then cause the satellite permanent failure. To prevent the failure caused by charging and arcing, it is necessary to investigate the mechanism of satellite charging and arcing phenomenon. The purpose of this paper is to investigate the occurrence condition of a secondary arc by measuring arc plasma characteristics in ground test. We measured the arc plasma temperature and identified the materials emitted using spectrometer at arbitrary time during arc occurring. We investigated the difference of secondary arcs occurrence condition during secondary arcs. From the spectroscopic measurement results, we found that it was necessary for shifting to the secondary arc that the metallic vapor same as the cathode material was emitted. In case of PA dimension changes, the probability of secondary arc and TSA occurrence became high. And plasma temperature was not affected by PA dimension. However, the metallic vapor emission of silver was greatly affected. Thus, secondary arc occurrence greatly depends on metallic vapor emission from cathode.

1. Introduction

In geostationary earth orbit (GEO), thin hydrogen plasma exists at density of 10^6m^{-3} . Substorm phenomenon sometimes occurs due to earth magnetic field disturbance according to the change of the solar wind. High energy electron flux of tens of keV flows into the satellite when the substorm occurs. In such an environment, arcs occur on the solar array and threaten the safe operation, as the bus power level of satellite increases. The arcs due to interaction between space plasma environment and solar array are serious problem for satellites [1]. Therefore, it is important to investigate the mechanism of the charging and arcing phenomena of the satellite.

When the satellite is charged, the coverglass potential can be higher than the interconnector potential which is equal to the spacecraft ground because of the difference in secondary emission yield. This is called the inverted potential gradient condition. When the inverted potential gradient is formed, the high electric fields are formed at the triple junctions. The electrons are emitted from the surface of the metal by the electron field emission. The secondary electron is emitted there by collide with side edge of the cover glass. Then, the electric field near the triple junction is enhanced further. As the field emission current increases, the gas desorption increases at side edge of the cover glass and forms the gas layer. The arc occurs by ionization in the gas [2]. This arc phenomenon is called primary arc. In addition, the solar array cell can be short-circuited with cell of adjacent strings through the arc plasma formed by primary arc and the arc causes short-circuit between adjacent strings with operational voltage (Fig.1). This

arc phenomenon is generally called secondary arc. If secondary arc occurs, the power cannot be supplied to the onboard instrument of satellite because the output power of the solar array circuit is lost by short-circuit between a positive electrode and a negative electrode.

The kind of arc is classified by the current waveforms flowing between adjacent strings as shown in Fig.2. Primary arc is an arc phenomenon that the charge stored on the cover glass flows into the arc spot through the arc plasma. This current that flows into electrode is called as a blow-off current. If there is no secondary arc after a blow-off current finishes, the arc is called the non-sustained arc (NSA). The temporary sustained arc (TSA) and the permanent sustained arc (PSA) are the arc phenomena

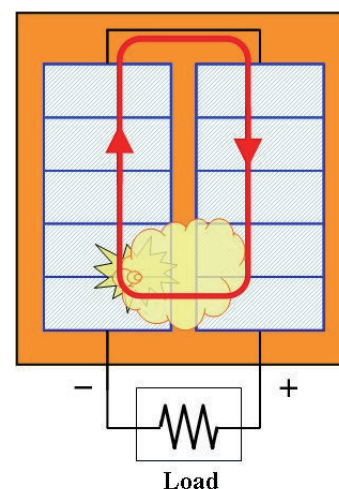

Fig.1 Current path of secondary arc.

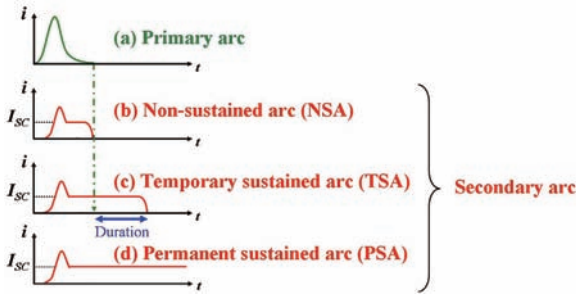

Fig.2 Definition of arc type based on current waveform.

that the current generated by solar cells flows into cells of adjacent strings through the arc plasma and is maintained even after blow-off current ends. This current flowing into the cells of adjacent strings is called as an arc current. Thus, arc plasma might be maintained or not even if the primary arcs are same. However, it is not yet well-known condition of maintained arc plasma which is occurrence condition of secondary arc.

Our purpose of this study is to find the occurrence condition of secondary arcs caused satellite failure by measuring the plasma temperature and the emission metallic vapors by spectroscopy. In this paper, we measured the emission spectrum of arc discharge in arbitrary timing. We calculated the arc plasma temperature associated with arc plasma conductivity, and identified the kind of material emitted from solar array due to arcs. We considered the difference in the property of the arc plasma between NSA and TSA during the secondary arc.

2. Experimental Setup

2.1 Solar Array Coupons

We used solar array coupons designed for Japanese satellite ETS-VIII [3], and composed of Si cells (70x35 mm). This coupon is for measurement it when arcs short-circuit between cells of adjacent strings (Fig.3).

Test coupon has no scar on the surface. We biased 4 cells of adjacent strings (masked cells in Fig.3), and examined the arc phenomena where arc occurs at between the different potential strings.

2.2 Experimental Setup

All experiments were performed in a vacuum chamber, which has 600mm in diameter and 900mm in length. The pressure in the chamber was less than 2×10^{-4} Pa during experiment. Figure 4 shows the experimental circuit to simulate charging and arcing on orbit. The electron beam gun (acceleration voltage 0~30kV, electronic current densities 0~200 μ A) (ULVAC: RHEED) simulates the high energy electron that flows into the satellite at the substorm. Moreover, high voltage power supply V_{bias} (0~60kV, 0~10mA) (Glassman: EW60R10) was used to simulate the potential of satellite sinking negatively during the

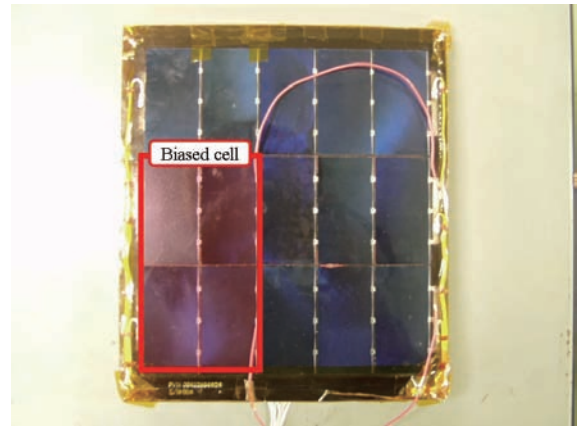

Fig.3 Overview of test coupon.

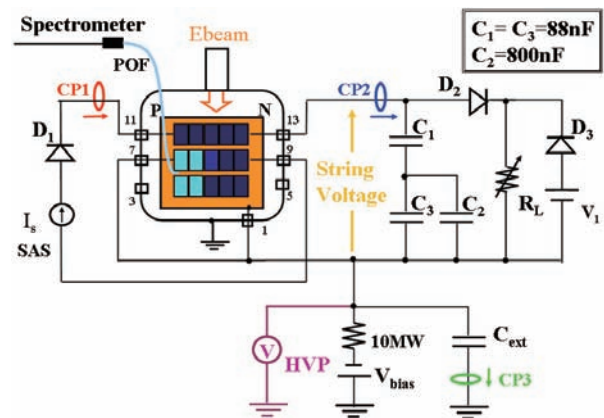

Fig.4 Experimental circuit.

substorm. In addition, a solar array simulator SAS (Agilent: E4351B) was used to simulate the power generation of solar array and supplied to the resistance R_L that simulated the load of the satellite. The voltage between strings was operational voltage of satellite. The C_{ext} that simulated the charge stored in other cover glass because the solar array of an actual size could not be put in the chamber.

When an arc occurs, electrons are emitted from C_{ext} and flow through the solar array, and then reach to the chamber wall through the arc plasma, and flow to the ground. In this case, the current measured at CP3 in the experiment circuit is called a blow-off current. In the case of NSA, the SAS keeps supplying the current to R_L after the blow-off current finished flowing. In the case of TSA, the current flows into the substrate and cannot flow to R_L because R_L is supplied with a voltage of V_1 which simulates generated voltage by other solar array.

2.3 Emission spectroscopy

In this experiment, the spectroscopy was carried out using a spectrometer (Hamamatsu Photonics: PMA11 C8808-01). It has the measurement range of wavelength of 200nm~860nm, the minimum time

resolution of 10ns, the wavelength resolution of 3.0nm. Moreover, a plastic optical fiber POF (Edmund: 53833-G) was attached to the detector to raise intensity from arc discharge.

The oscilloscope outputs the trigger signal to a delay pulse generator DPG (Stanford Research: DG-535) detecting a rising edge of a blow-off current when the arc occurs. The trigger signal is sent to the DPG and makes a TTL and an ECL signal to the spectrometer. The emission spectrum from arc is taken by the detector at time that ECL signal rise. Spectrum acquisition in arbitrary timing after the arc becomes possible by changing delay time (Delay) and pulse width (Gate) of the ECL signal.

The data base of NIST [4] was used to identify of the measured spectrum. C₂ swan band spectrum (420nm~530nm) with high reproducibility was used to calculate of the temperature of plasma. C₂ swan spectrum at from 2,000K to 7,000K is open to the public in BESP [5]. Figure 5 shows C₂ swan spectrum at 6,000K. We paid attention to the area ratio of the first mountain to the second mountain. The correlation with the temperature and the area ratio is shown in Figure 6. It was found that the temperature was represented by the area ratio using the regression curve of exponential.

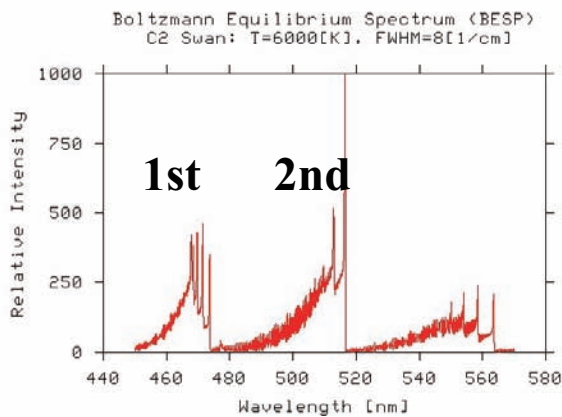

Fig.5 C₂ swan Spectrum in 6,000K (BESP).

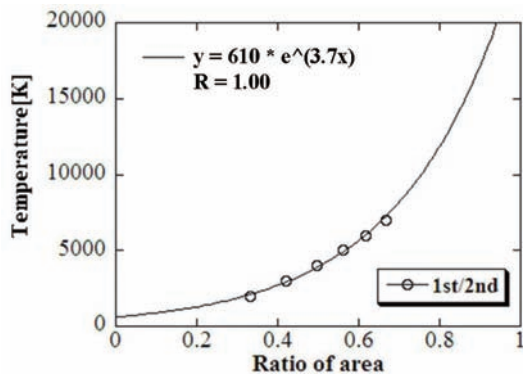

Fig.6 Relation between ratio and temperature of area.

3. Experimental result and discussion

Table 1 shows the experimental parameter used in this experiment. The experiments was performed at about $2\sim 8 \times 10^{-4}$ Pa. The string voltage is potential difference between two adjacent solar array strings. The I_s is the current supplied from SAS.

3.1 Experiment of arcs at string gap

Time variation of arc plasma temperature for PA and TSA

This experiment was carried out by the parameter in Table1 excluding the following parameters (I_s=1.2A, Gate: 2.5μsec). Table 2 lists the number of arcs measured during this experiment. There was no NSA in this experiment. There are two types of TSA, TSA-Hot is that t arcs occur at the high potential cell's electrode, TSA-Rtn is that arcs occur at the low potential cell's electrode.

Figure 7 shows plasma temperature distribution to time variation for PA and TSA. The time in a blow off current ending is defined as 0μsec (Time=0μsec). As shown in Fig.7, there is no difference in temperature distribution while a blow off current is flowing in PA and TSA.

Table 1 Experimental parameter

Back Pressure	2x10 ⁻⁴ Pa ~ 2x10 ⁻³ Pa	
C _{ext}	20nF, 30nF, 45nF, 65nF	
V _s	70V, 90V, 105V	
I _s	0.05A, 0.1A, 0.2A, 0.5A, 1.2A	
V _{bias}	-7kV	
Electron Beam	7.2keV ~ 8keV, 100μA	
Spectrometer	Gate	1μsec, 2.5μsec
	Delay	0 ~ 30μsec
	Gain	6 or 8

Table 2 Number of arcs at string gap

Is [A]	Arcs at gap	PA	TSA-Hot	TSA-Rtn
1.2	10	9	18	22

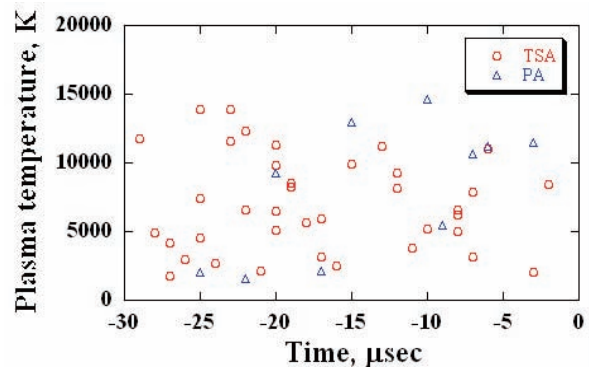

Fig.7 Plasma temperature distribution to time variation for PA and TSA.

Relation between arc plasma temperature and TSA duration

Figure 8 shows that relation between arc plasma temperature and TSA duration before primary arc finished. As shown in Fig.8, the TSA duration did not depend on the plasma temperature. If the plasma temperature rises up to some degree, it might be unrelated to TSA duration.

Identification of material that is emitted from solar array coupon

We examined the relative intensity of silver that was composing the cell's electrode. Figure 9 and 10 show the spectrum of PA and TSA. We found that silver metallic vapor (masked area in Fig.) was emitted much in case of TSA than that in case of PA.

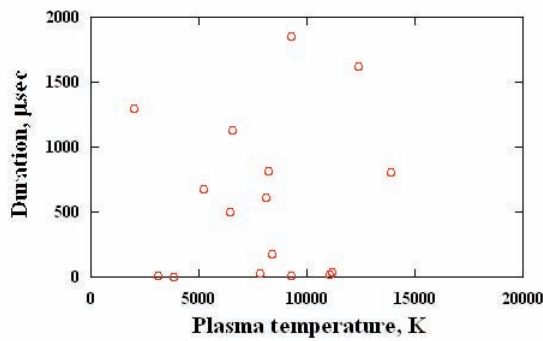

Fig.8 Relation between arc plasma temperature and TSA duration.

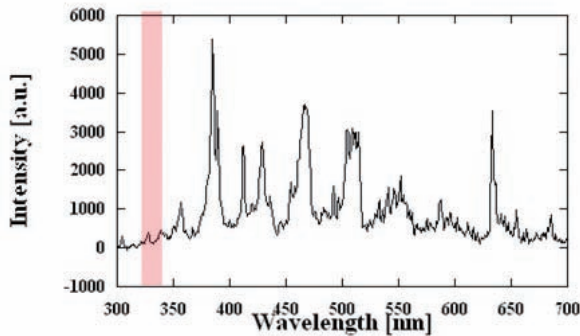

Fig.9 Arc spectrum of PA.

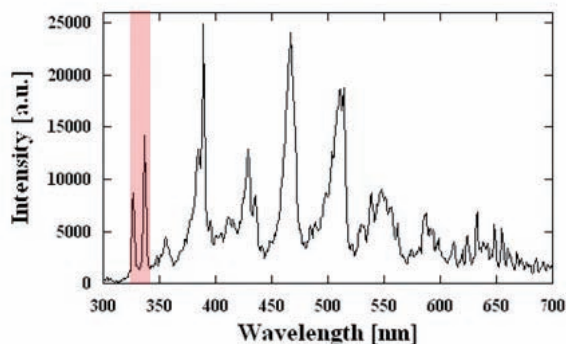

Fig.10 Arc spectrum of TSA.

Relation between emitted metallic vapor and probability of TSA transition

The condition of shifting from PA to TSA was considered by focusing on relative intensity of spectrum of Ag I. Figure 11 shows the relation between probability of shifting to TSA and relative intensity of Ag I and first peak of C₂ molecular. C₂ molecular was measured reproducibly at each spectrum. This figure shows that the probability of arc shifting to TSA was high if the amount of silver metallic vapor which composes the cell's electrode was emitted much.

Relation between emitted metallic vapor and TSA duration

Figure 12 shows that relation between relative metallic vapor emission of silver and TSA duration before primary arc finished. As shown in Fig.12, the TSA duration became long if the emitted metallic vapor was much before arc shifting to TSA. The duration of TSA is proportional to amount of emitted metallic vapor.

Relation between metallic vapor emission and arc current

We focused on the source of the metallic

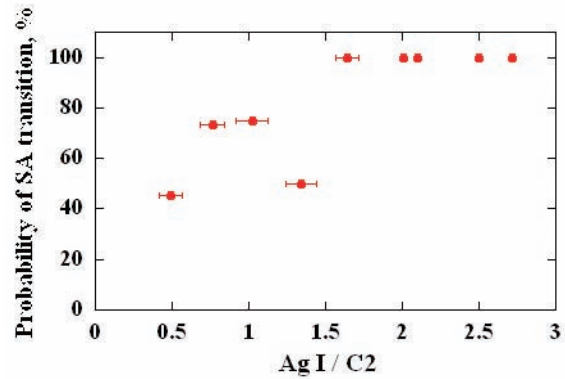

Fig.11 Probability of shifted to TSA for arcs at string gap.

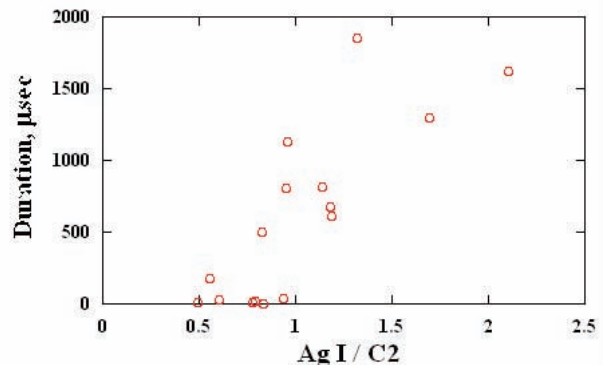

Fig.12 Relation between relative intensity of metallic vapor emission and TSA duration.

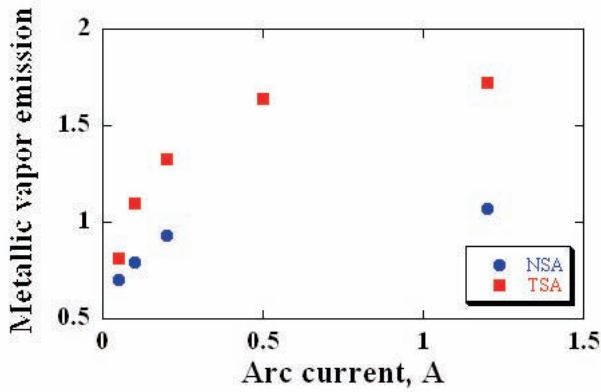

Fig.13 Relation between arc current and amount of emitted metallic vapor.

Table3 PA parameter

Vst [V]	Ist [A]	Cext [nF]	Blow-off current		
			Peak [A]	Pulse width [μsec]	Charge [μC]
70	0.2	30	20.4	18.5	150.3
		45	31.2	19.8	218.1
		65	45.6	17.8	307.3

Table4 Number of arcs

Vst [V]	Ist [A]	Cext [nF]	Number of arcs			
			Total	PA	NSA	TSA
70	0.2	30	20	14	5	1
		45	20	11	5	4
		65	11	4	2	5

vapor emission of silver. In case of generally arcs, metallic vapor is emitted from cathode because the arc current flow into there. Fig.13 shows that relation between metallic vapor emission and arc current.

We found that there is strong relation between secondary arc occurrence condition and metallic vapor emission of silver.

3.2 The effect of PA dimension

We considered the primary arc energy due to external capacitance. Table 3 lists the parameter of PA during this experiment. We carried out the low string current experiment to observe only the effect of PA dimension. In this experiment, we investigate the effect of PA dimension against plasma condition at gap in detail.

SA&TSA probability for external capacitance

First, we investigated whether probability of secondary arc occurrence changes by PA dimension (the value of external capacitance, C_{ext}) Table 4 shows the experimental result of C_{ext} experiment. This is result of number of arcs at gap. From this result, we calculated the probability of secondary arc (SA) and

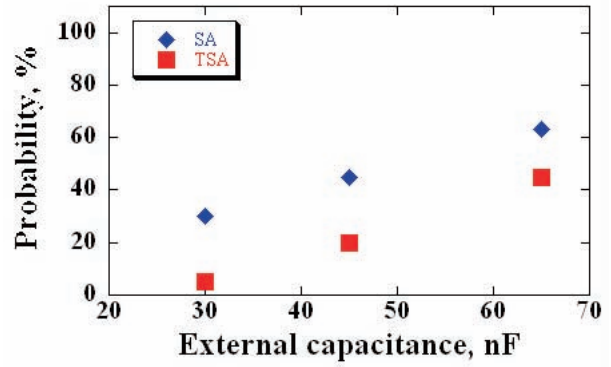

Fig.14 SA&TSA probability for external capacitance.

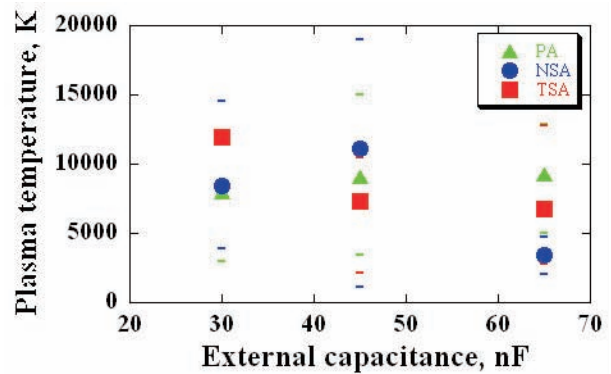

Fig.15 Plasma temperature for external capacitance.

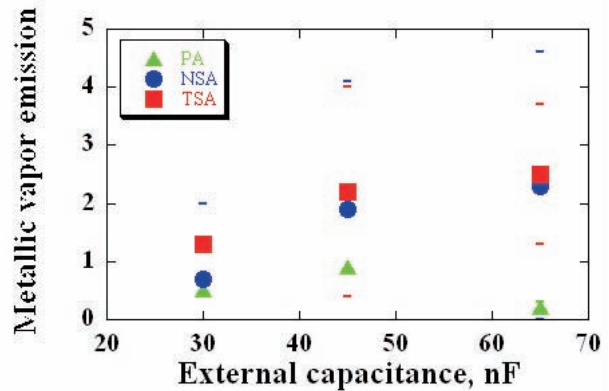

Fig.16 Metallic vapor emission for external capacitance.

temporary sustained arc (TSA) occurrence. Fig.14 shows the calculation result. We found that the bigger PA dimension become, the higher probability of SA and TSA occurrence become.

Plasma temperature during PA

We investigated whether plasma temperature at gap during PA changes by PA dimension. Fig.15 shows the plasma temperature for PA dimension. The error bar means the minimum and maximum value of plasma temperature. We could not determine that the plasma temperature depended on the PA dimension.

Metallic vapor emission during PA

We investigated whether metallic vapor emission of silver at gap during PA changes by PA dimension. The relation of metallic vapor emission and PA dimension is shown in Fig.16. The error bar means the minimum and maximum value of metallic vapor emission of silver. This figure shows that the metallic vapor emission depended on PA dimension.

4. Summary

In this paper, we identified the material emitted by arc and calculated the arc plasma temperature by means of applying spectroscopy on arc discharge.

We investigated the difference of secondary arcs occurrence condition during secondary arcs. From the spectroscopy results, we found that it was necessary for shifting to the secondary arc that the metallic vapor same as the cathode material was emitted. And, TSA duration depends on metallic vapor emission. In case of PA dimension changes, the bigger PA dimension become, the higher probability of SA and TSA occurrence become. And, the metallic vapor emission of silver was greatly affected by PA dimension. However, plasma temperature was not affected by PA dimension. Thus, secondary arc occurrence greatly depends on metallic vapor emission from cathode.

We could investigate the plasma condition due to secondary arcs occurrence. In the future, we must investigate it more detail, and we must consider that the effect of point and shape of cathode spot on secondary arc occurrence. Then, we must investigate

the countermeasures method against secondary arcs.

References

- [1] Katz, I., Davis V.A; and Snyder, D.B, "Mechanism for Spacecraft Charging Initiated Destruction of Solar Arrays in GEO", AIAA 98-1002, 36th Aerospace Sciences Meeting & Exhibit, Reno, January, 1998
- [2] Cho, M., and Fujii, H., "Review on Charging and Discharging Phenomena in Space Environment: Arcing on High Voltage Solar Array and Future Issues", Aeronautical and Space Sciences Japan, Vol.51, pp.139-145, 2003
- [3] M.Takahashi, H.Nishimoto, S.Kawakita, M.Cho, Y.Nozaki, H.Fujii, Y.Murakami, T.Ozaki, N.Onodera, "ETS-VIII Solar PDL Plasma Interaction Problem Approach", 7th Spacecraft Charging Technology Conference, Noordwijk, Netherlands, April, 2001
- [4] NIST Atomic Spectra Database http://physics.nist.gov/cgi-bin/AtData/lines_form
- [5] Boltzmann Equilibrium Spectrum Program <http://view.utsi.edu/besp/>
- [6] Jeongho Kim, Seiji Aso, Satoshi Hosoda, Mengu Cho, "Threshold Conditions to Induce the Sustained Arc on the Solar Array Panel of LEO Satellite", 9th Spacecraft Charging Technology Conference, Tsukuba, Japan, April, 2005